



The automatic hot-melt adhesive filling system Series TWISTER F-15 may be installed and used on any existing gluing system. It permits glue to be loaded into the machine automatically and maintains the glue level constant in the tank without needing the intervention of an operator. TWISTER F-15, with absolutely dependable technical characteristics, consists of essentially two main elements: the control unit and the suction pump. The control unit is connected to a sensor that detects the level of the adhesive inside the melting tank. When the level is low, a precise signal is sent to the suction pump, which intervenes by loading small quantities of glue with the goal of keeping the tank constantly full, and in this way avoiding carbonization and exposition of the glue to external contaminants. Installing the TWISTER F-15 system requires less than one hour of time, a power outlet and an air supply feed.

TWISTER F-15 technical features guarantee a return on the investment in only 6 months; thanks to the automatic glue refill the manual intervention by the operator will be drastically reduced generating a considerable saving in maintenance costs for the whole system and warranting no machine downtime caused by glue shortages in the tank. Further advantages using TWISTER F-15 are the elimination of risks for the operator of contact with hot glue and no risk of contaminating the glue with external agents keeping the original adhesive properties, reducing carbonization process and avoiding thermal shock dangerous for the correct conservation and adhesive use.



CONTROL UNIT

The control unit, complete with microprocessor, controls and manages all phases of loading of the glue from the storage container to the melting tank. The system also has a button for manual loading. Another useful, practical and original feature that distinguishes the Twister F-15 from the competition is the possibility to unhook the control unit from the storage container.



CONVEYOR CONE

Made entirely of stainless steel, this part directs the granules of adhesive into the melting tank without dispersion. Its cone-shaped form was specifically designed, and allows it to be used on all existing systems, no matter what the brand or type of machine.



LEVEL SENSOR

A special lance probe is inserted inside the melting tank. The probe detects variations in the level of glue with absolute precision, and sends load and stop signals to the suction pump.

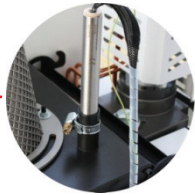

HERMETIC CLOSING SYSTEM

The hermetic system for the connection of glue and air tubes and the protection filter installed on the bin side, allow to use TWISTER F-15 avoiding the risk of contaminating the glue with external agents keeping the original adhesive properties, reducing carbonization process.



VIBRATION SYSTEM

A particular vibration system connected with the suction pump prevents lumps from forming in the glue, which could block the suction process.



SUCTION PUMP

A system of suction works through an innovative, powerful Venturi pump that was completely designed by Preo, built in stainless steel and treated Ergal. The suction pump does not contain any moving parts, thus excluding the possibility of mechanical failure and eliminating time needed for maintenance.





TECHNICAL SPECIFICATIONS

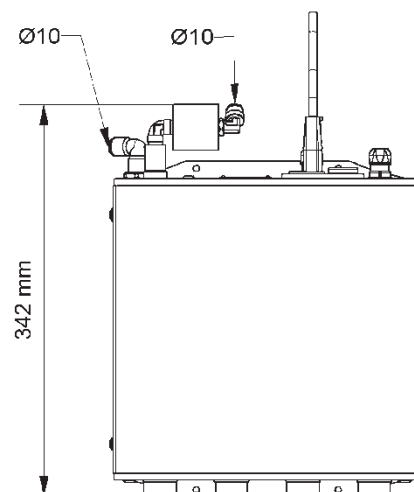
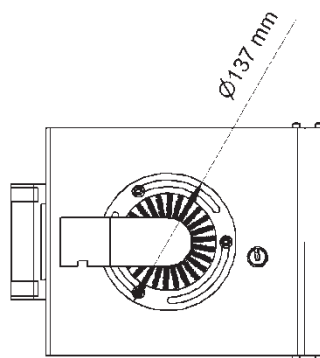
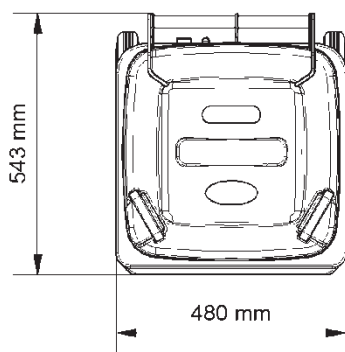
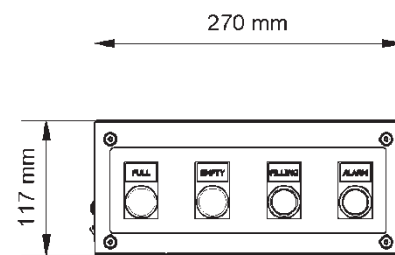
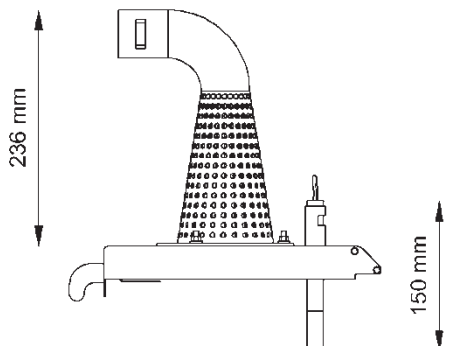
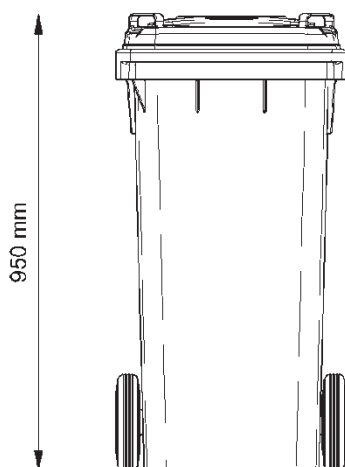

GENERAL SPECIFICATIONS

ADHESIVE TYPOLOGY AND VISCOSITY	pellets or tablets \varnothing 12 mm 0,472 in)
ADHESIVE TRANSFER SPEED	200 kg/h (440 lb) depending on used adhesive typology
TRANSFER TUBE LENGTH	4 m (13,12 ft)
WEIGHT (EMPTY)	20 kg (44,1 lb)
STORAGE CONTAINER CAPACITY	60 kg (132 lb)
CONTROL PANEL DIMENSIONS (L x H x W MM)	270 x 117 x 342 mm
GRID DIMENSIONS	0,45 x 0,45 mm
CONE HEIGHT	236 mm
FILLING	dry with no lubricant
PUMP TYPE	Venturi designed and built by Preo S.r.l.
NOISE	76 dbA

ELECTRICAL SPECIFICATIONS

VOLTAGE	1/N/PE AC 230 V \pm 10% 50/60 Hz, 1/N/PE AC 115 V \pm 10% 50/60 Hz (on request)
POWER CONSUMPTION	50 W (0,5 A)

PNEUMATIC SPECIFICATIONS

AIR CONNECTION	tube \varnothing 10 mm
MINIMUM WORKING AIR PRESSURE	6 bar (0,6 Cps o 87 psi)

© Copyright 2012 PREO SRL - All rights reserved - Subject to change without advanced notice - Printed in Italy - Edition EN-200 TWISTER F-15 - 18/05/2012

PREO S.r.l.

Via Alessandro Volta, 7 • 20094 Corsico (MI) • Italia
 tel. (+39) 02 48601260 • fax (+39) 02 4503323
 www.preo.it • italia@preo.it • world@preo.it



YOUR
 QUALITY
 CHOICE